

Drum Scrubber (DS)

PureAIR
FILTRATION

Economical, Durable Deep Bed Design

SPECIFICATIONS:

Applications	Wastewater odor removal
Airflow Range	0 CMH (0 CFM) – 2,123.7 CMH (1,250 CFM) <i>*Please review the model selection sheet for more information</i>
Configuration	Vertical airflow
Construction Material	Standard: High-density polyethylene (HDPE) Other options: Stainless Steel, Fiberglass reinforced plastic
Particulate Filtration	Odor Control Applications: Mist and Grease Filter Other Applications: 5 cm (2 in), 30% MERV 8 Prefilter, 15 cm (6 in), 95% MERV 13 Final Filter <i>*Other filter sizes/options available upon request. Please contact the factory for more information.</i>
Blower Configuration	DRAWTHRU: Standard and allows the blower to work in clean air, thus making it last longer and require less maintenance <i>*Redundant blowers and other special options available</i>
Customizable	Multiple sizes and configurations available, reference model selection chart for details. Add-on accessories like sound enclosures are available. Contact factory for more information. <i>*Don't see what you are looking for? PureAir specializes in customization. Contact us with your air filtration needs and we will work with you to find the best solution.</i>



BENEFITS:

- Low maintenance: Ease of replacing and disposing of spent media
- Multiple beds available for adsorbent media. For more information on the adsorbent media, please see the media brochure

MEDIA BED INDICATOR:



This unit is equipped with a metal media bed indicator. The device is positioned inside the system at an angle against the direction of airflow and detects the media expiration level.

- Dark, corroded coloration on indicator shows where media has expired. Once half the device has been corroded, contact the factory to replace the media and ensure the continued proper functioning of the system.
- Interested in instant notification of media life? Ask about the electronic media bed monitor (EBMv2) that can be added as a system upgrade.



Case Study
City of Camas

+1 678.935.1431 | Toll Free: 866.543.7479

www.PureAirFiltration.com | 6050 Peachtree Pkwy, Suite 240-187, Atlanta, GA, 30092 USA



MODEL SELECTION TABLE

DS MODEL #	AIR FLOW RANGE CMH (CFM)	MOTOR RANGE kW (HP)	MEDIA VOLUME M ³ (FT ³)*	Shipping Weight KG (LBS)	Operating Weight KG (LBS)
100	85 - 170 (50 - 100)	.37 (.5)	.14 (5)	79 (175)	156 (345)
300	170 - 510 (100 - 300)	.56 (.75)	.25 (10)	154 (340)	304 (670)
500	510 - 850 (300 - 500)	.75 (1)	.42 (17)	113 (250)	386 (850)
1000	850 - 1700 (500 - 1000)	1.1 (1.5)	1.1 (39)	272 (600)	862 (1900)

* Special Airflows are Available

Notable Customers:

- Byrne Hollow Farms
- Dean Foods
- Town of Strasburg
- Coney Island WWTP
- LOVECO
- CTI Beanmaker
- Wahoo Creek Influent PS
- Belmont County Fairgrounds
- Imperial Landfill

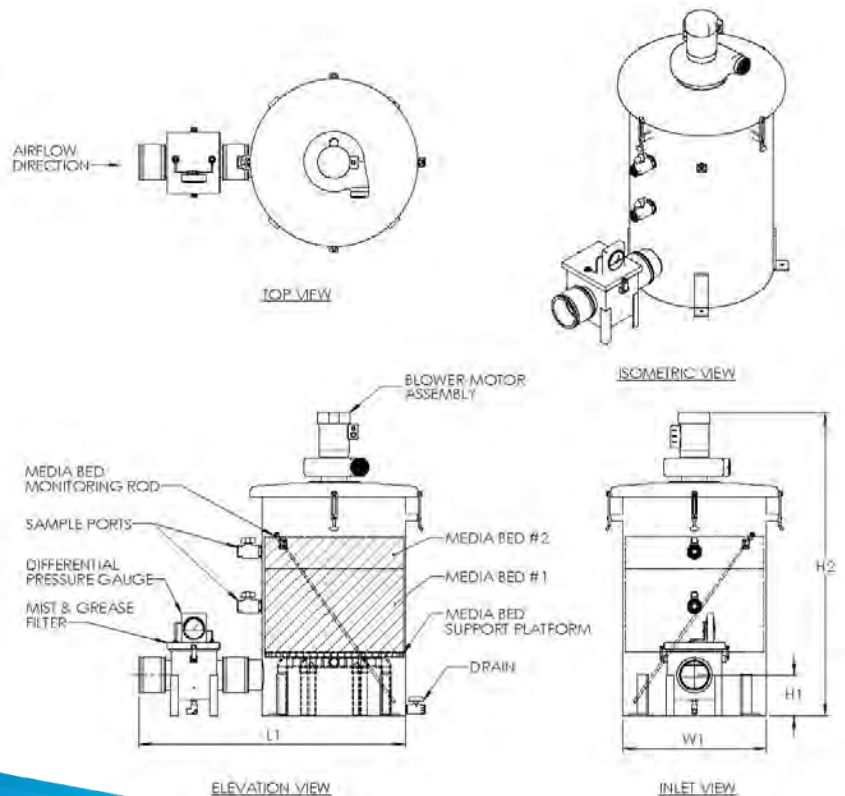

+1 678.935.1431

Toll Free: 866.543.7479

www.PureAirFiltration.com

6050 Peachtree Pkwy, Suite 240-187, Atlanta, GA, 30092 USA